

DIFFERENTIAL PRESSURE TRANSMITTERS

Same Size as Standard Magnehelic® Differential Pressure Gage



DM-2000-LCD



DM-2100-LCD

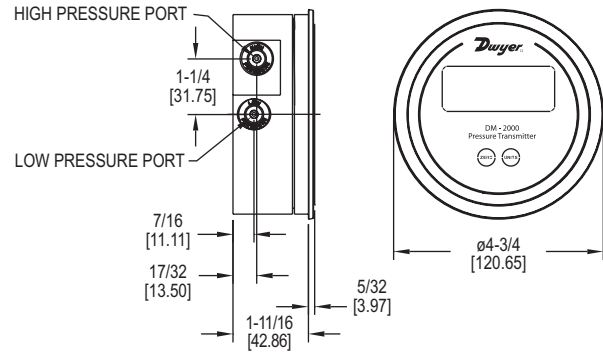

The Dwyer Series DM-2000 Differential Pressure Transmitters sense the pressure of air and compatible gases and sends a standard 4-20 mA output signal. The DM-2000 housing is specifically designed to mount in the same diameter cutout as a standard Magnehelic® gage. A wide range of models are available factory calibrated to specific ranges.

Pressure connections are inherent to the glass filled plastic molded housing making installation quick and easy. Digital push-button zero and span simplify calibration over typical turn-potentiometers. An optional 3.5 digit LCD shows process and engineering units. A single push-button allows field selection of 4 to 6 engineering units depending on range.

FEATURES/BENEFITS

- Zero and span controls provide easy calibration checks and shorter installation time to get device running and monitoring
- Quick response to pressure changes means no delay in signaling and alerting to critical situations
- Easy to read LCD display provides immediate local alerts allowing corrective action to be taken quicker to eliminate the problem from becoming widespread
- Same size as Magnehelic® simplifies field upgrade to digital pressure gage by reducing install steps
- Tamper proof button configuration to prevent accidental changes to the settings

APPLICATIONS

- Differential pressure across filters
- Fan control
- Static pressures in ducts or buildings

MODEL CHART						
Model	Range (in w.c.)	Pa	mm w.c.	mBar	kPa	psi
DM-2001-LCD	0 to .100	24.9	2.54	.249	-	-
DM-2002-LCD	0 to .250	62.2	6.35	.622	-	-
DM-2003-LCD	0 to .500	124.3	12.70	1.243	.124	-
DM-2004-LCD	0 to 1.000	249	25.4	2.49	.249	-
DM-2005-LCD	0 to 2.00	497	50.8	4.97	.497	-
DM-2006-LCD	0 to 3.00	746	76.2	7.46	.746	.108
DM-2007-LCD	0 to 5.00	1243	127.0	12.43	1.243	.180
DM-2012-LCD	0 to ±.250	0 to ±62.2	0 to ±6.35	0 to ±.622	-	-
DM-2013-LCD	0 to ±.500	0 to ±124.3	0 to ±12.70	0 to ±1.243	-	-
DM-2019-LCD	0 to ±.200	0 to ±49.8	0 to ±5.08	0 to ±.498	-	-

Note: For white overlay change -20 to -21. **Example:** DM-2102-LCD

SPECIFICATIONS

- Service:** Air and non-combustible, compatible gases.
- Wetted Materials:** Consult factory.
- Accuracy:** ±1% FS, ±30 Pa model ±4% FS at 70°F.
- Stability:** ±1% FS/yr.
- Temperature Limits:** 20 to 120°F (-6.67 to 48.9°C).
- Pressure Limits:** 10 psig (0.69 bar).
- Thermal Effect:** ±0.055% FS/°F (0.099% FS/°C), ±30 Pa model ±0.13% FS/°F (0.234% FS/°C).
- Power Requirements:** 10-35 VDC (2 wire).
- Output Signal:** 4-20 mA.
- Zero and Span Adjustments:** Digital push-button zero and span.
- Loop Resistance:** DC: 0 to 1250 Ω maximum.
- Current Consumption:** DC: 38 mA max.
- Electrical Connections:** Screw-type terminal block.
- Display:** 3.5 digit LCD, 0.7" H.
- Process Connections:** 1/8" ID tubing.
- Mounting Orientation:** Vertical.
- Weight:** 4.8 oz (136 g).

ACCESSORIES	
Model	Description
A-299	Surface mounting bracket
A-300	Flat flush mounting bracket
A-302F-A	303 SS static pressure tip with mounting flange; for 3/16" ID rubber or plastic tubing; 4" insertion depth; includes mounting screws
A-320-A	Instrument enclosure
A-489	4" straight static pressure tip with flange
SCD-PS	100-240 VAC/VDC to 24 VDC power supply

OPTIONS	
To order add suffix:	Description
-NIST	NIST traceable calibration certificate
Example: DM-2002-LCD-NIST	
-FC	Factory calibration certificate
Example: DM-2002-LCD-FC	